

Anglo-Chinese School (Junior)



END-OF-YEAR EXAMINATION (2025)

PRIMARY 5

SCIENCE

BOOKLET A

Thursday

30 October 2025

1 hr 45 min

Name: _____ () Class: 5.()

INSTRUCTIONS TO PUPILS

- 1 Do not turn over this page until you are told to do so.
- 2 Follow all instructions carefully.
- 3 There are 30 questions in this booklet.
- 4 Answer all questions.
- 5 Use a 2B pencil to shade your answers on the Optical Answer Sheet (OAS).

This booklet paper consists of 18 printed pages.

For each question from 1 to 30, four options are given. One of them is the correct answer. Make your choice (1, 2, 3 or 4) and shade your answer on the Optical Answer Sheet.
(60 marks)

1. Which of the following characteristics is true for all living things?

- (1) They can make their own food.
- (2) They give birth to their young alive.
- (3) They need air, food and water to survive.
- (4) They can move from place to place by themselves.

2. Study the classification chart.

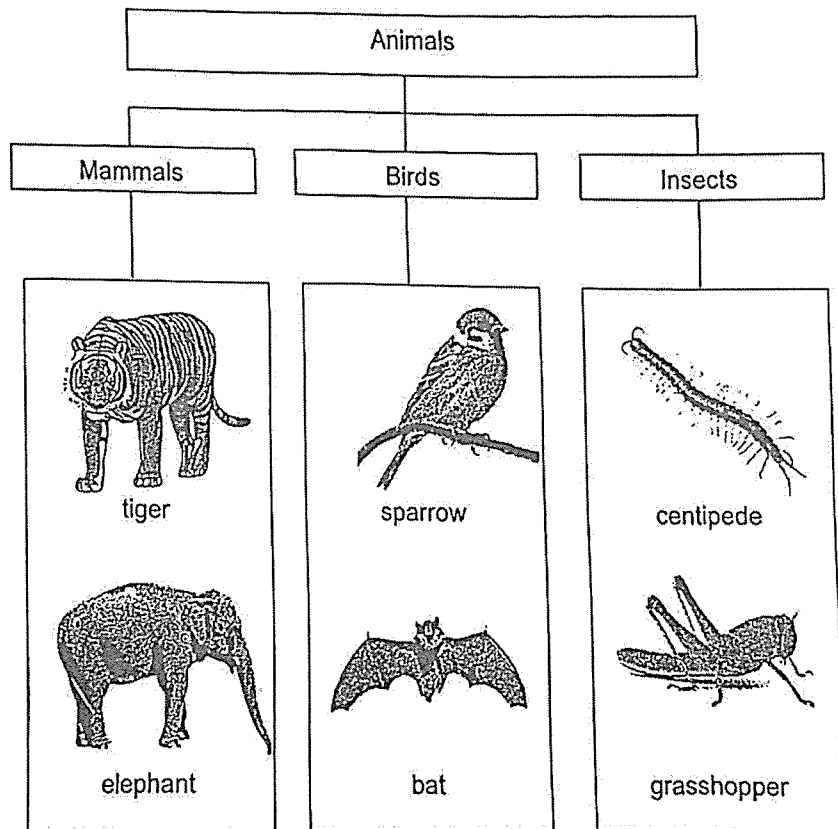

Which of the following two animals are placed in the incorrect group?

- (1) tiger and bat
- (2) bat and centipede
- (3) centipede and sparrow
- (4) elephant and grasshopper

3. The table shows the different characteristics of living things, X, Y and Z. A tick (✓) shows that the living thing has that characteristic.

Characteristic	X	Y	Z
Able to make food		✓	
Reproduce by spores		✓	
Can be used to make bread	✓		
Can only be seen with a microscope	✓		✓

Which of the following correctly represents X, Y and Z?

	X	Y	Z
(1)	bacteria	mould	yeast
(2)	yeast	fern	bacteria
(3)	bacteria	fern	mould
(4)	yeast	mould	bacteria

4. The diagram shows the life cycle of a butterfly and a grasshopper.

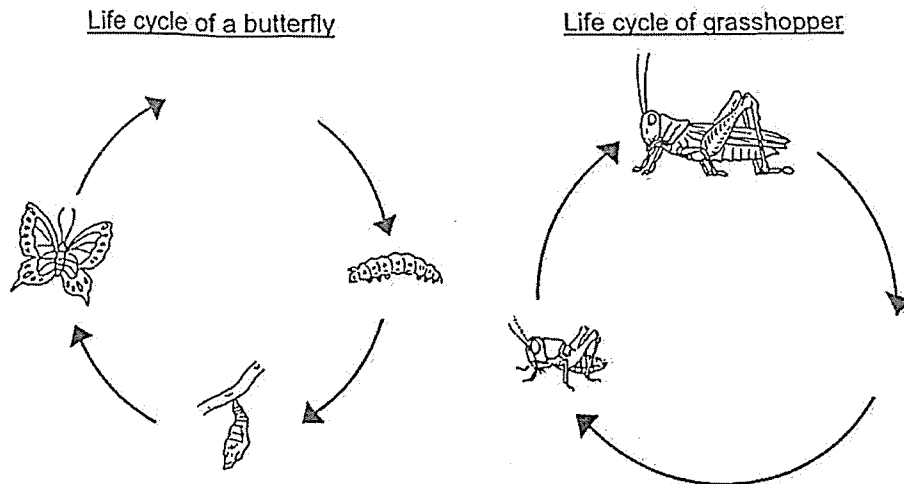

What is the similarity between the two life cycles?

- (1) Both start with the egg stage.
- (2) Both animals at the adult stage can fly.
- (3) Both spend part of their life cycle in water.
- (4) Both have the same number of stages in their life cycle.

5. Study the flowchart.

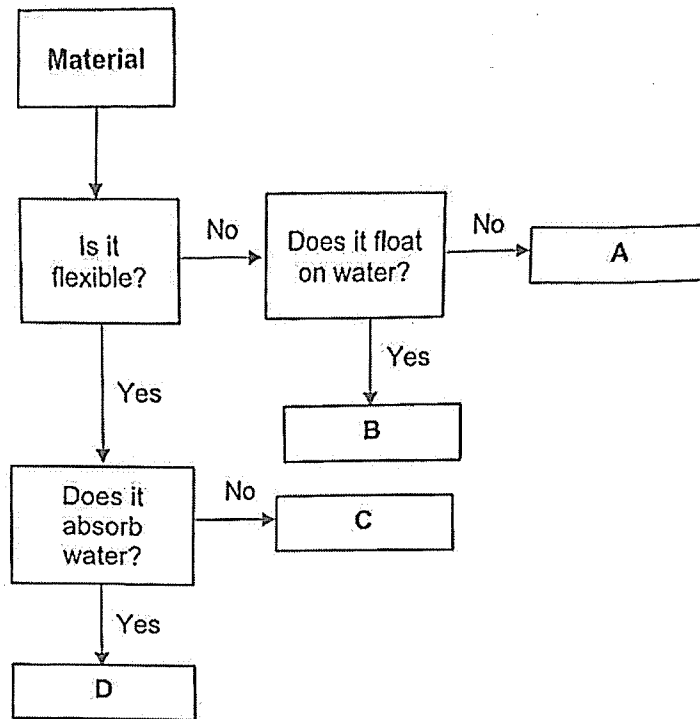

Which material, A, B, C or D, is most suitable for making part X of the camping tent shown?

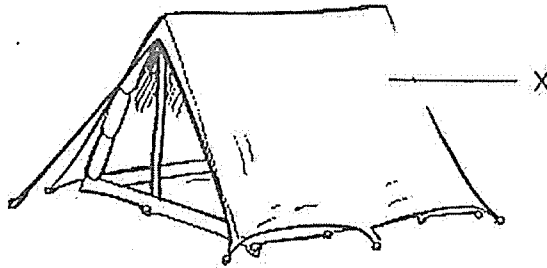

- (1) A
- (2) B
- (3) C
- (4) D

6. Munirah conducted an experiment to find out if warmth is needed for seeds to germinate. The table shows the conditions of the four set-ups.

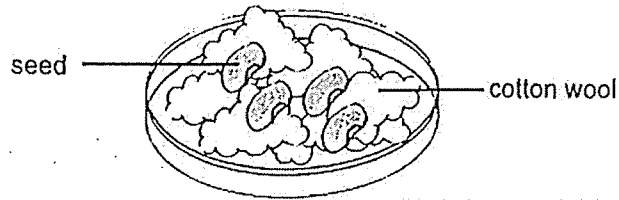

Set-up	Conditions	
A	dry cotton wool	in the refrigerator
B	wet cotton wool	in the refrigerator
C	dry cotton wool	near the window
D	wet cotton wool	near the window

Which two set-ups should Munirah use to carry out her experiment?

- (1) A and C
 - (2) A and D
 - (3) B and C
 - (4) B and D
7. Lionel tried to pump more air into a fully inflated ball.

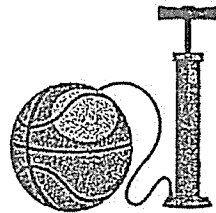

What would happen to the volume and mass of air in the ball if he were to pump another 50 cm³ of air into the ball?

	Volume of air	Mass of air
(1)	Increased	Increased
(2)	Increased	No change
(3)	No change	No change
(4)	No change	Increased

8. Study the flow chart.

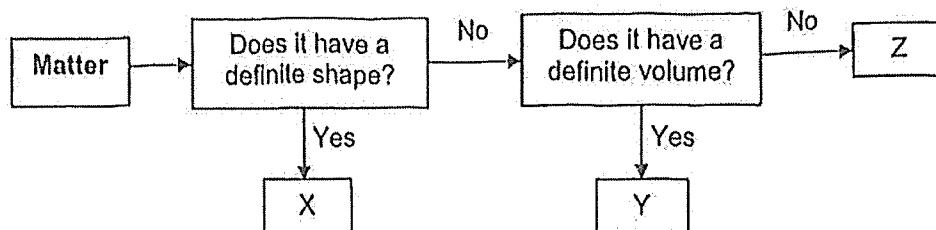

Which of the following most likely represent matter X, Y and Z?

	X	Y	Z
(1)	eraser	milk	water vapour
(2)	milk	eraser	water vapour
(3)	eraser	water vapour	milk
(4)	water vapour	milk	eraser

9. The diagrams show the human reproductive systems P and Q.

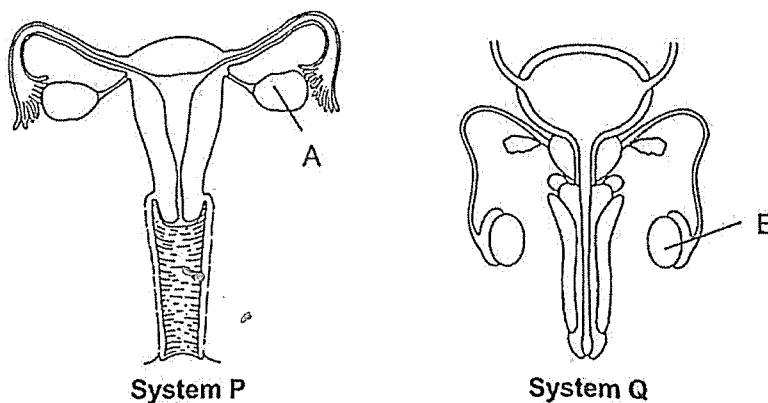

Which one of the following statements about the systems is correct?

- (1) Baby develops at part A.
- (2) Fertilisation occurs inside System Q.
- (3) Parts A and B produce reproductive cells.
- (4) Part B produces the female reproductive cells.

10. Which seed W, X, Y or Z is most likely dispersed by the splitting method?

Seed	Characteristics		
(1) W	Small	Light	It has hooks.
(2) X	Small	Light	It has a wing-like structure.
(3) Y	Small	Light	The fruit is hard and dry when ripe.
(4) Z	Big	Heavy	The fruit has a fibrous husk.

11. Hannah observed a flower and recorded her observation on her notepad as shown.

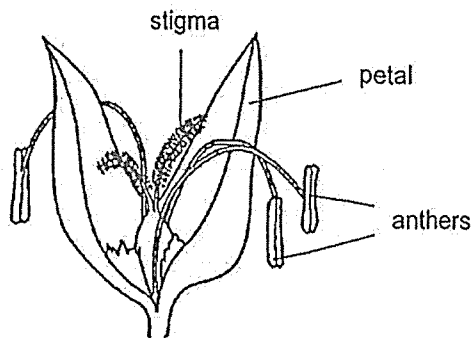

- flower has no scent
- some pollen grains found on stigma
- anthers dangling outside the petals

Based on her observations, which two of the following inferences could Hannah make?

- A The flower is dying.
- B Pollination has taken place.
- C The flower is pollinated by wind.
- D The flower is pollinated by insects.

- (1) A and D
- (2) A and C
- (3) B and C
- (4) B and D

12. The table shows the boiling and melting points of three substances, A, B and C.

Substances	Melting Point (°C)	Boiling Point (°C)	State of substance at room temperature (25°C)
A	10	30	X
B	5	60	Y
C	1	20	Z

Based on the table, which one of the following best describes X, Y and Z?

	X	Y	Z
(1)	Liquid	Liquid	Gas
(2)	Liquid	Solid	Gas
(3)	Gas	Solid	Solid
(4)	Solid	Gas	Liquid

13. The diagram shows the processes that take place in the water cycle.

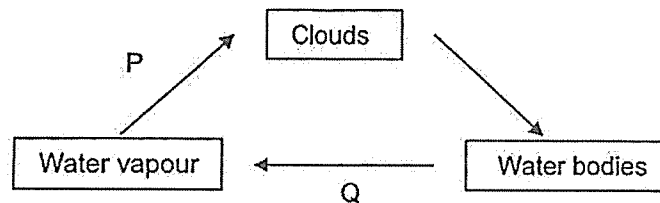

What are the processes, P and Q?

	P	Q
(1)	Evaporation	Evaporation
(2)	Evaporation	Condensation
(3)	Condensation	Evaporation
(4)	Condensation	Condensation

14. The graph shows the change in temperature of substance M as it is being heated under a flame for 20 minutes.

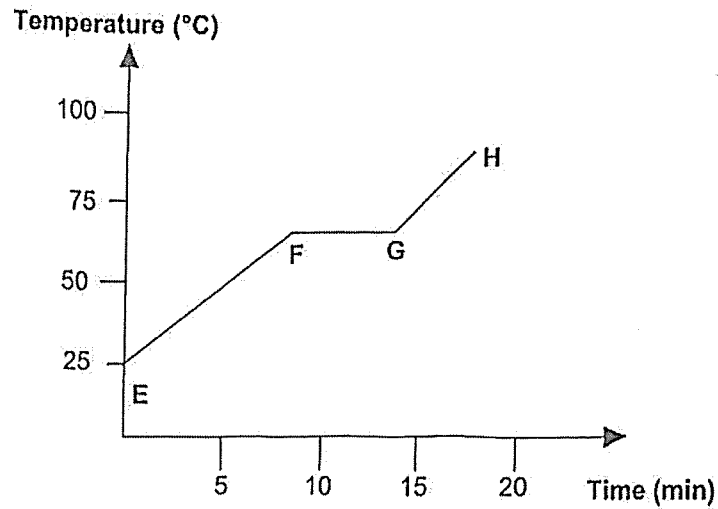

Which part(s) of the graph show(s) that substance M is melting?

- (1) EF
 (2) FG
 (3) GH
 (4) EF and GH
15. The diagram shows how some objects interacted with one another.

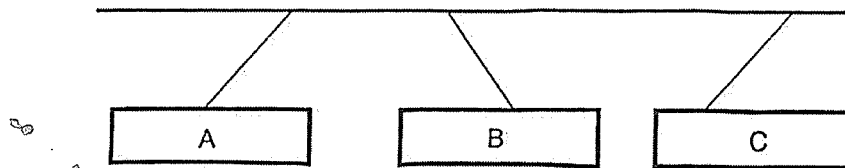

Which one of the following best represents objects A, B and C?

	A	B	C
(1)	magnet	iron nail	magnet
(2)	iron nail	steel bar	steel pin
(3)	magnet	magnet	steel bar
(4)	iron nail	steel pin	magnet

16. The diagrams show the arrangements of some bar magnets.

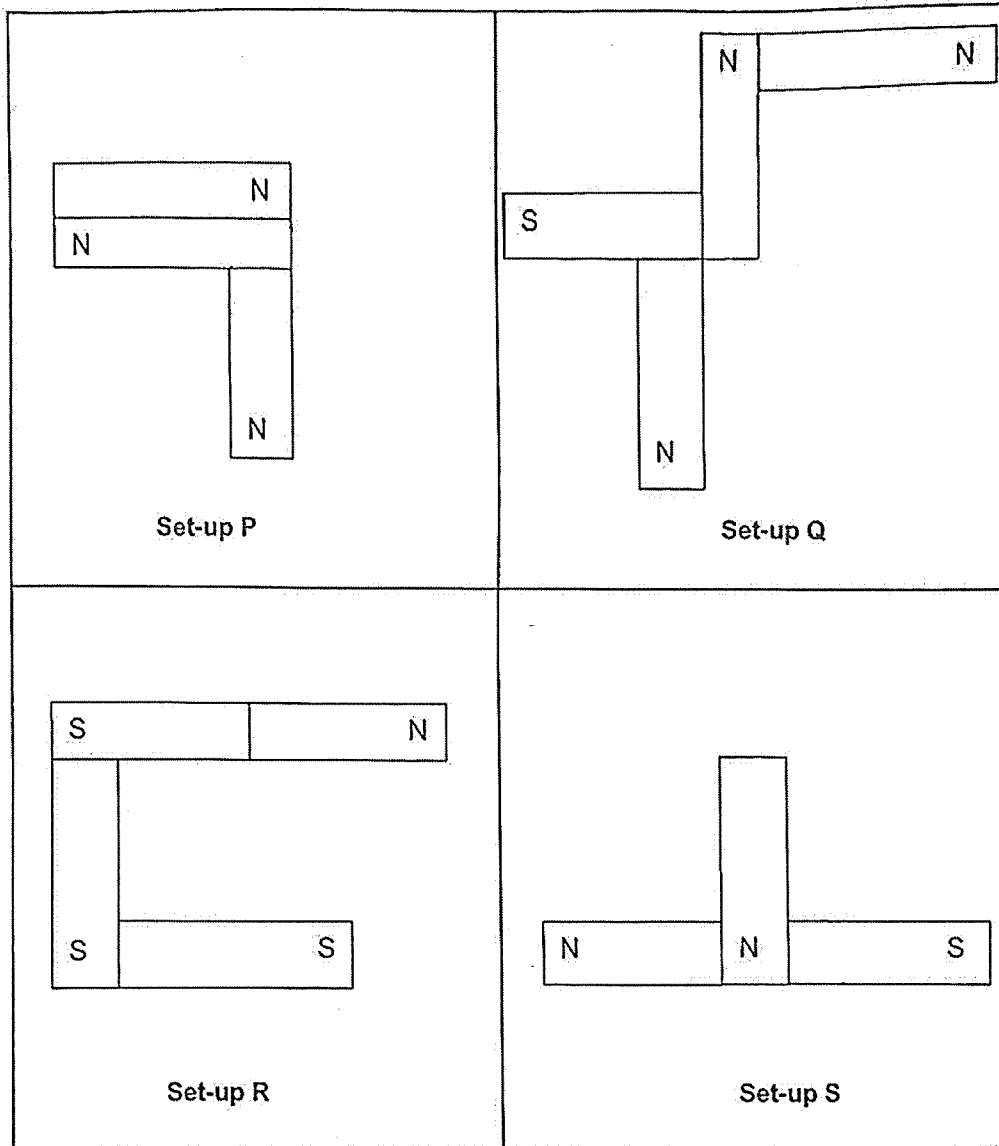

Which set-ups are **not** possible?

- (1) P and Q
- (2) P and S
- (3) Q and R
- (4) R and S

17. Sharon played with some slime as shown. She can see the beads and glitter dust inside the slime.

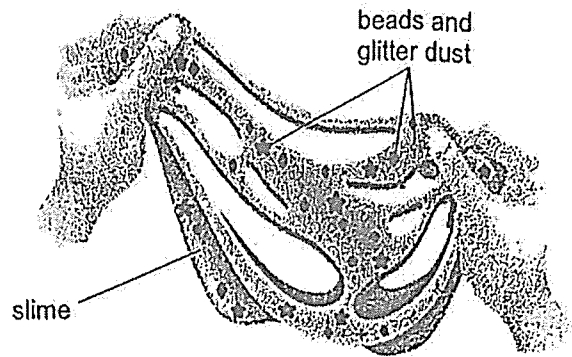

Which of the following shows the correct properties of the slime?

	allows light to pass through	reflects light
(1)	No	Yes
(2)	No	No
(3)	Yes	No
(4)	Yes	Yes

18. A wooden block is placed 4 cm from a torch.

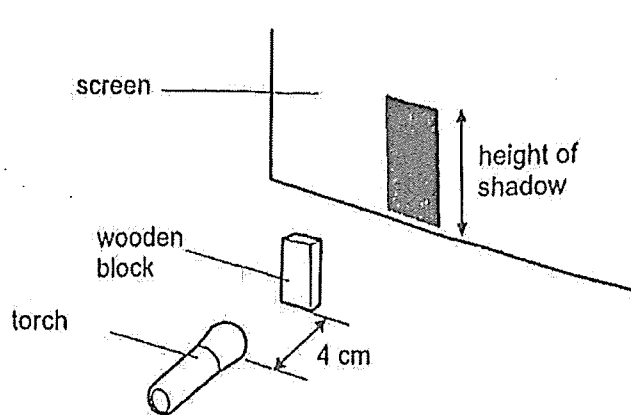

The wooden block is then moved towards the screen.

Which graph shows how the height of the shadow changes as the distance between the torch and the wooden block increases?

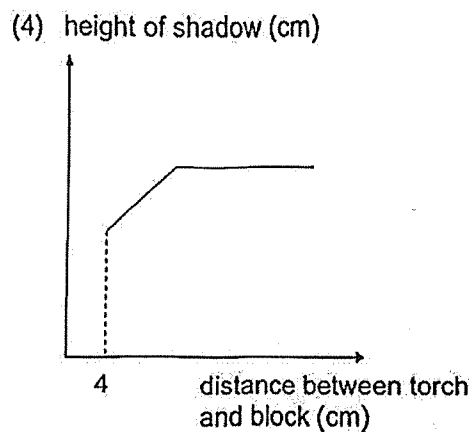
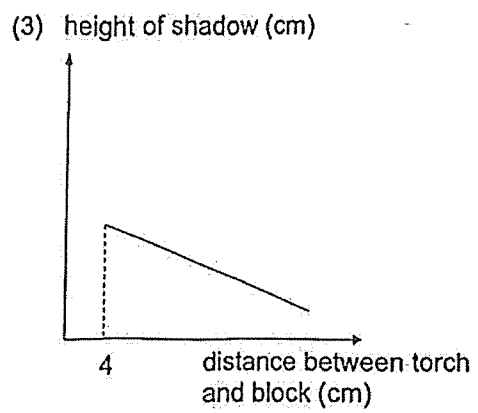
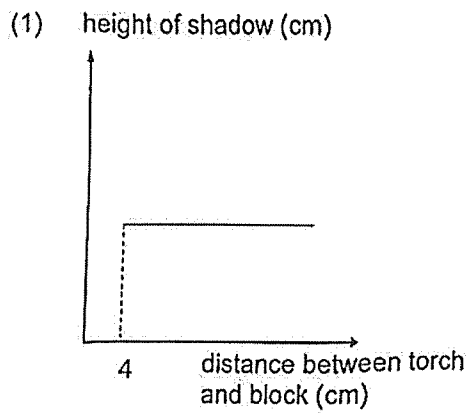

19. Aiden and Adam were each given an identical scoop of ice cream in identical cups at the same time at a restaurant, as shown. Aiden's ice cream soon began to melt.

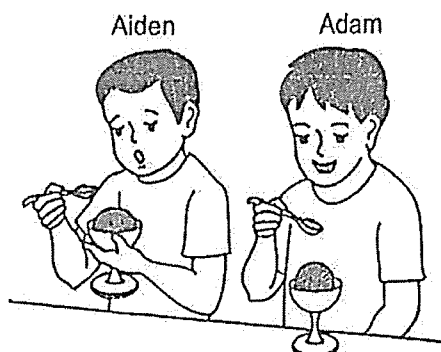

Which statement explains why Aiden's ice cream is melting faster than Adam's?

- (1) Aiden's ice cream had a larger exposed surface area.
 - (2) Aiden's ice cream was gaining more heat from the cup.
 - (3) Aiden's ice cream was losing more heat than Adam's ice cream.
 - (4) Temperature of Aiden's ice cream was lower than the surroundings.
20. Four beakers of water at $30\text{ }^{\circ}\text{C}$ were heated with identical Bunsen burners. The picture shows the temperature of water after they were heated.

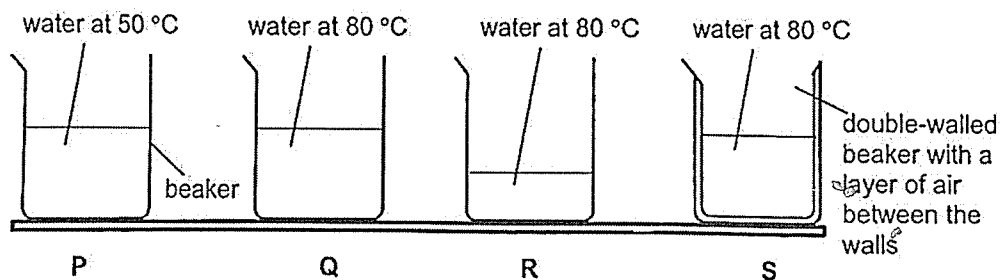

Which beaker of water took the longest time to reach the temperature shown?

- (1) P
- (2) Q
- (3) R
- (4) S

21. Two metal pots which were slacked together got stuck after a while.

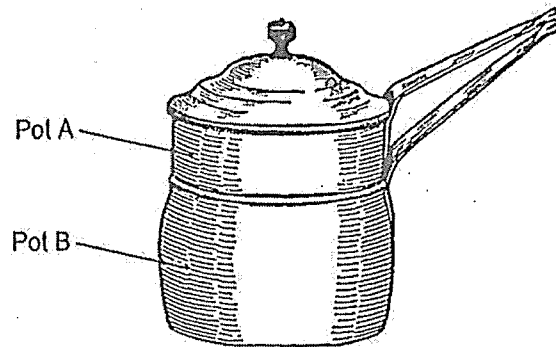

What can be done to separate the metal pots?

- A Place pot B over the fire.
 B Pour hot water into pot A.
 C Pour cold water into pot A.
 D Place pot B in a tub of cold water.
- (1) A only
 (2) A and C only
 (3) B and D only
 (4) C and D only
22. The diagram represents the flow of blood towards and away from the small intestine through blood vessels X and Y.

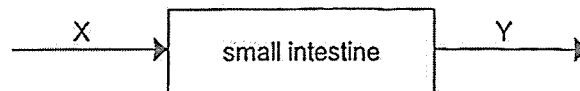

Which of the following shows the **incorrect** amount of substances in the blood at X and Y?

	X	
(1)	More oxygen	Less oxygen
(2)	More waste materials	Less waste materials
(3)	Less carbon dioxide	More carbon dioxide
(4)	Less digested food	More digested food

23. The table shows the types of gases in air that are taken in and given out by a human.

Gas	Air taken in (%)	Air given out (%)
carbon dioxide	less than 1	4
nitrogen	78	78
oxygen	21	16
water vapour	less than 1	2

Based on the information given, which statement is not correct?

- (1) Water is lost through breathing.
 - (2) Not all the oxygen that enters the lungs goes into the blood.
 - (3) Carbon dioxide produced by the body is released into the air.
 - (4) Only three types of gases enter the human respiratory system.
24. The diagram shows how digested food and various gases are transported in the human body.

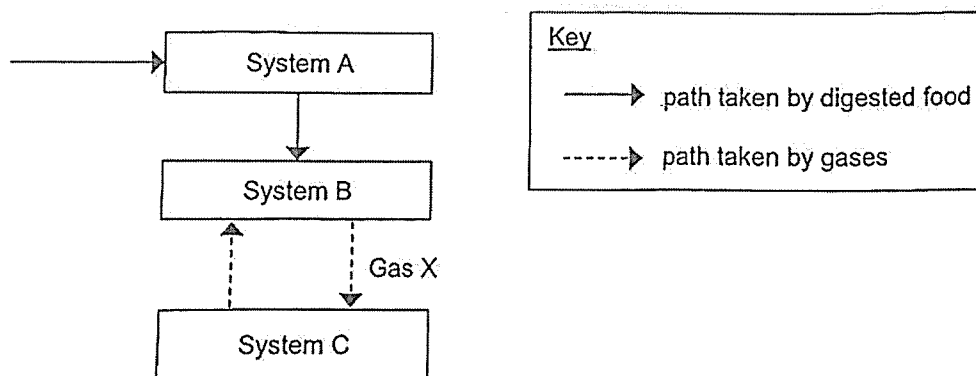

Which systems do A, B and C represent and what is gas X?

	System A	System B	System C	Gas X
(1)	circulatory	respiratory	digestive	oxygen
(2)	digestive	circulatory	respiratory	oxygen
(3)	digestive	circulatory	respiratory	carbon dioxide
(4)	circulatory	digestive	respiratory	carbon dioxide

25. Study the plant.

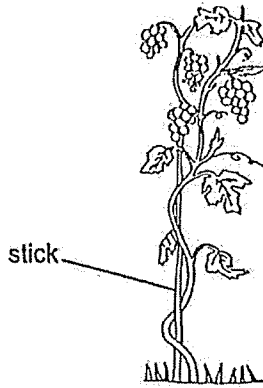

Which statement(s) is/are true about the plant?

- A It has a weak stem
- B It does not have roots.
- C It reproduces by seeds
- D It has smooth edged leaves.

- (1) A only
- (2) A and C only
- (3) B and D only
- (4) B, C and D only

26. Ali wrapped and tied a black plastic bag around part of a plant as shown.

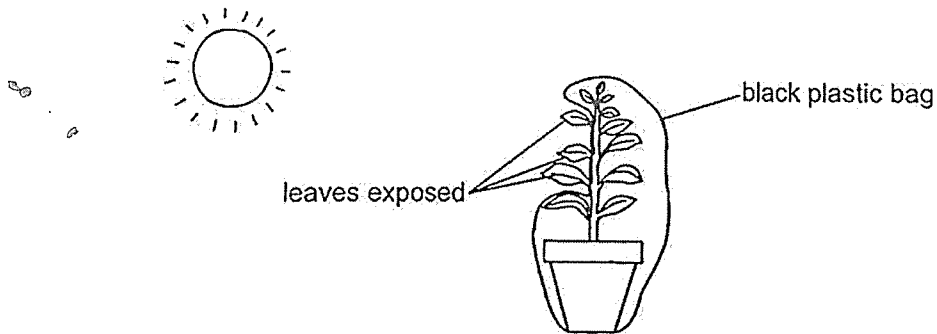

Food produced by the exposed leaves is transported _____ (A)
by _____ (B).

	(A)	(B)
(1)	upwards only	water-carrying tubes
(2)	downwards only	food-carrying tubes
(3)	upwards and downwards	food-carrying tubes
(4)	downwards only	both water and food-carrying tubes

27. Aaron set up an experiment as shown to find out whether plants take in water through their roots.

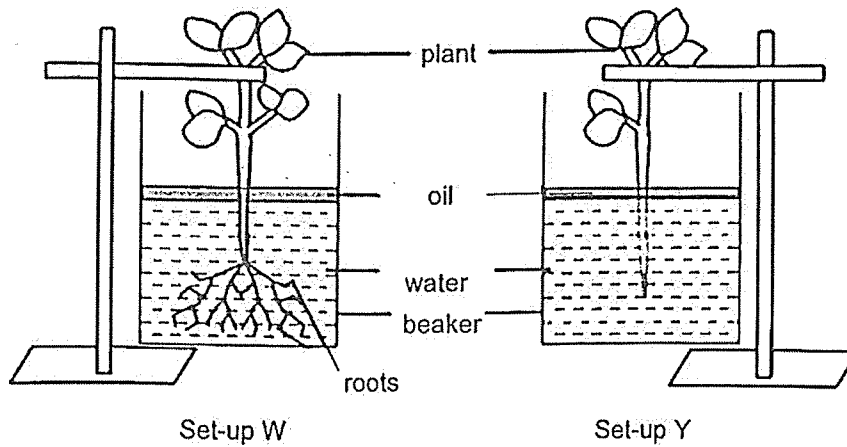

Aaron's teacher commented that the experiment is not a fair one. Which of the following explains why the teacher said so?

- (1) Set-up Y should not have oil.
 - (2) Both the set-ups should use different types of plants.
 - (3) Both the plants should have the same number of leaves.
 - (4) Plants in both set-ups should have the same amount of roots.
28. Andy was given a light bulb as shown.

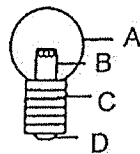

Which of the following shows the correct classification of the parts labelled A to D?

	Insulator	Conductor
(1)	A	B, C and D
(2)	A and B	C and D
(3)	C and D	A and B
(4)	B, C and D	A

29. Study the circuits. All the bulbs and batteries are new and identical.

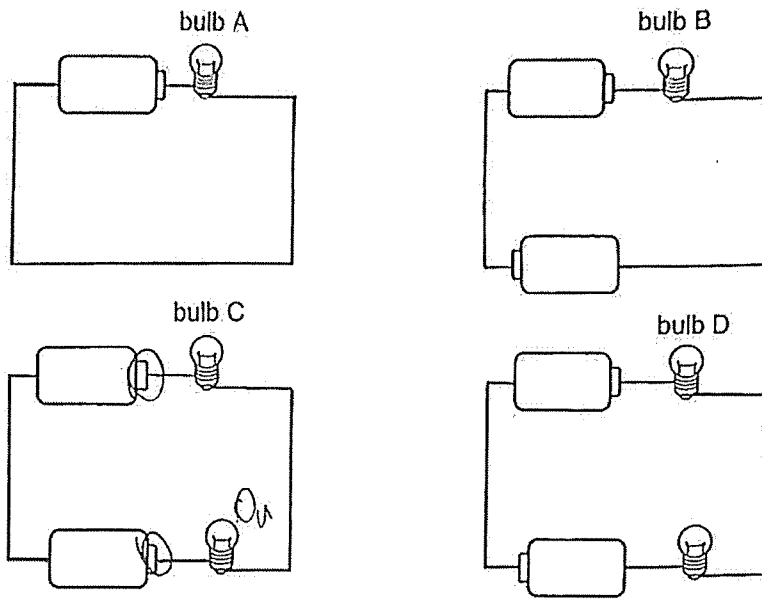

Which of the following two bulbs have the same brightness?

- (1) A and B
- (2) A and D
- (3) B and C
- (4) C and D

30. Study the circuit as shown.

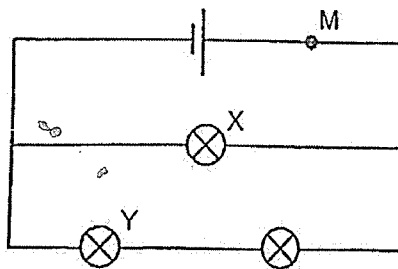

Which of the following components, when added at M, causes the correct change in brightness of bulbs X and Y?

	Component added at M	Brightness of X	Brightness of Y
(1)		Increase	Remain the same
(2)		Increase	Increase
(3)		Decrease	Decrease
(4)		Increase	Remain the same

End of Booklet A

Anglo-Chinese School (Junior)



END-OF-YEAR EXAMINATION (2025)

PRIMARY 5

SCIENCE

BOOKLET B

Thursday

30 October 2025

1 hr 45 min

Name: _____ () Class: 5.() Parent's Signature: _____

INSTRUCTIONS TO PUPILS

- 1 Do not turn over this page until you are told to do so.
- 2 Follow all instructions carefully.
- 3 There are 11 questions in this booklet.
- 4 Answer all questions.
- 5 The marks are given in the brackets [] at the end of each question or part question.

Booklet	Possible Marks	Marks Obtained
A	60	
B	40	
Total	100	

This booklet consists of 14 printed pages.

For questions 31 to 41, write your answers in this booklet. The number of marks available is shown in brackets [] at the end of each question or part question. (40 marks)

31. Alia set up an experiment with three strips of similar size but made of different materials, A, B and C as shown.

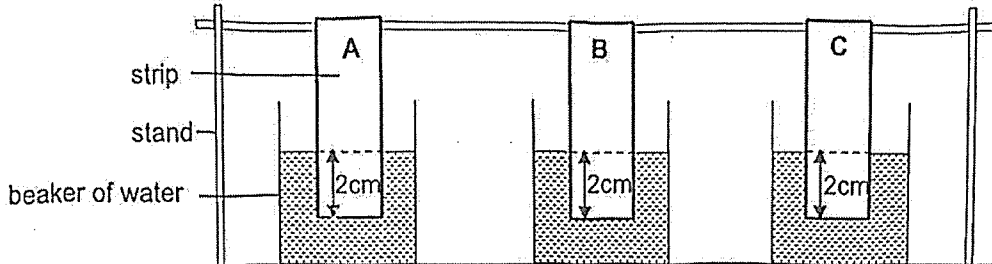

Her results are shown in the table below.

Material	Volume of water in the beaker (ml)	
	At the start	After five minutes
A	200	130
B	200	200
C	200	100

- (a) Arrange the materials, A, B and C, starting from the one that is most absorbent:

[1]

_____ , _____ , _____
 most

- (b) Alia chose material B to make a raincoat. Explain her choice based on the results and the property of material.

[2]

(Go on to the next page)

SCORE	/
	3

32. (a) Classify the following into matter and non-matter.

[1]

oxygen	sand	light
--------	------	-------

Matter	Non-matter

Amy filled two identical syringes with substances P and Q. She put an equal volume of each substance into each syringe.

She then pushed the plunger in as far as she could and measured distance X as shown.

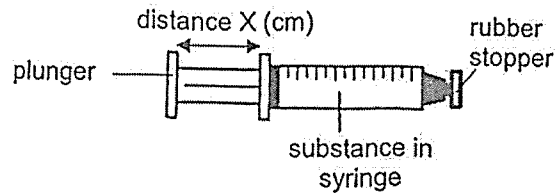

Amy recorded her results in the table.

Substance	Distance X (cm)	
	Before pushing plunger	After pushing plunger
P	8	8
Q	8	2

(b) Which substance, P or Q is likely to be a gas? Explain your answer.

[2]



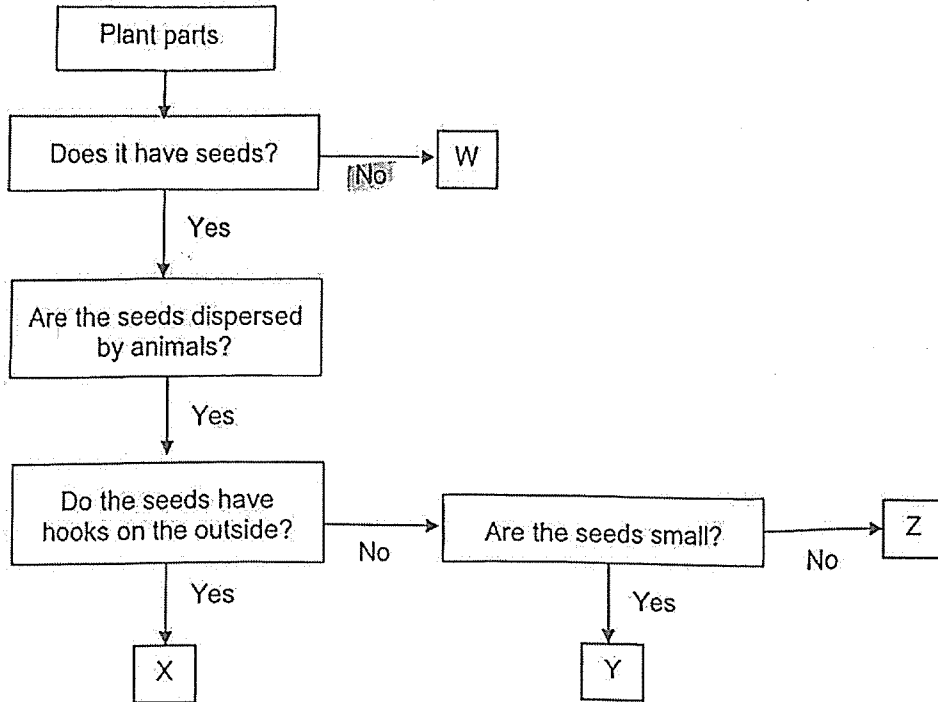

(Go on to the next page)

SCORE	3
-------	---

33. Study the flowchart shown.



(a) Based on the chart above and the diagram of the plant parts below, write the letters W, X, Y or Z in the boxes below. [2]

Plant part	Letter
	
	
	
	

(Go on to the next page)

SCORE	2
-------	---

(b) State one characteristic of Z that enables it to be dispersed by animals. [1]

(c) Describe how X is dispersed by animals. [1]

(Go on to the next page)

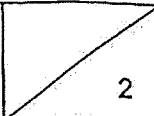
SCORE	
-------	---

34. Ben was driving a car along the road. He noticed that the windows of his car had become misty. The temperature of the surrounding air outside the car was 10°C and the temperature inside the car was 26°C .

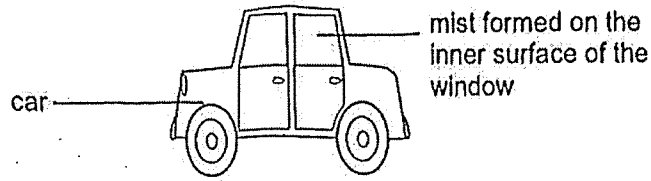

- (a) Name the state of mist. [1]

- (b) Explain how the mist was formed. [2]

- (c) How will the amount of mist formed change when he decreased the temperature in the car? Explain why. [1]

- (d) Ben stopped the car and wound down only one of the car windows. After some time, the mist disappeared.

Name the process that caused the mist to disappear. [1]

(Go on to the next page)

SCORE	5
-------	---

35. Brenda conducted an experiment using identical nails A and B, and new identical batteries as shown.

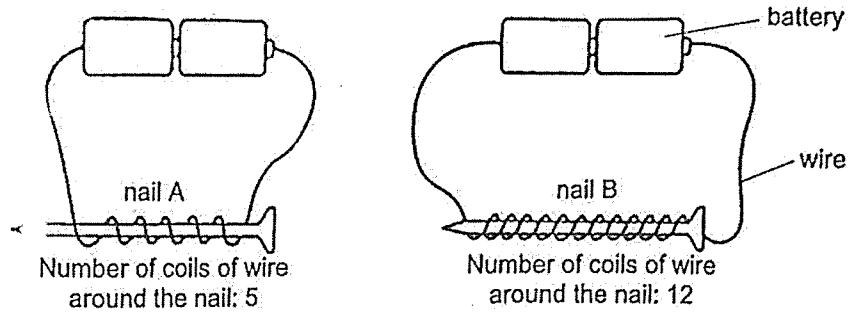

She recorded the number of steel pins attracted to the nails in the table.

Nail	Number of steel pins attracted
A	7
B	15

- (a) State the aim of her experiment. [1]

- (b) Brenda made two changes to the set-up with nail A to find out how the number of batteries affects the number of steel pins attracted. State the two changes she made. [2]

Change 1:

Change 2:

(Go on to the next page)

SCORE	3
-------	---

36. Ahmad wanted to find out how the number of leaves affects the volume of tap water taken in by the roots of the plant. He prepared four set-ups, A, B, C, and D, with the same plant in identical jars, each containing the same volume of oil on the surface as shown.

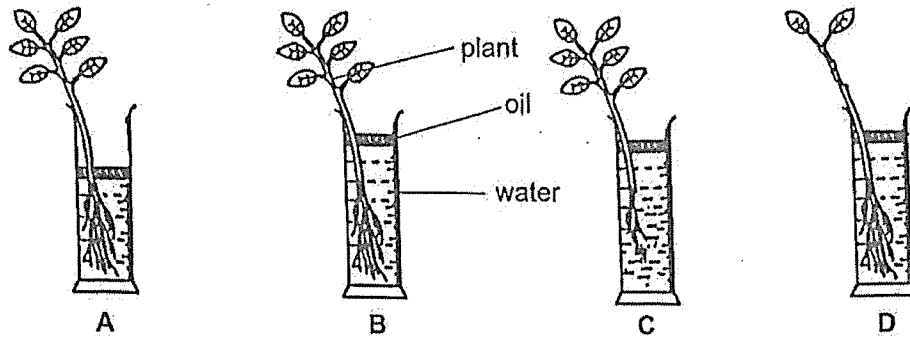

He measured the amount of water left in each jar after a week.

- (a) Which two set-ups, A, B, C or D, should Ahmad compare to conclude his experiment? Explain your answer. [1]

- (b) State another variable that Ahmad needs to keep constant for the set-ups chosen in (a) to ensure a fair test. [1]

- (c) State another function of the roots that is not shown in this experiment. [1]

(Go on to the next page)

SCORE	3
-------	---

37. The diagram shows a human body system.

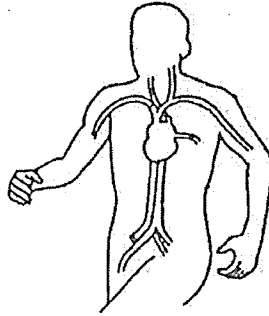

(a) Identify the system and state the function of the system. [1]

(b) Name two parts of this system. [1]

(c) Describe how the respiratory system works together with the above system to supply oxygen to all parts of our body. [2]

(Go on to the next page)

SCORE	
-------	--

38. The diagram shows how substances are transported in a plant. The arrows represent the movement of substances X and Y.

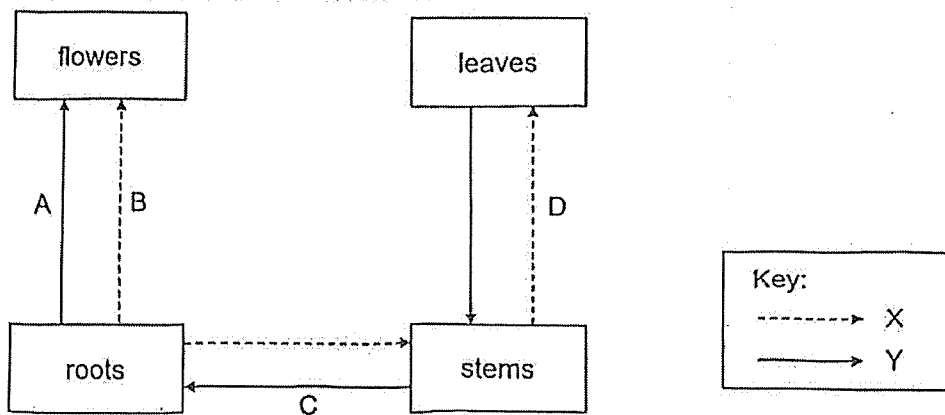

(a) Which two arrows, A, B, C or D, are wrongly drawn? [1]

(b) Identify substances X and Y. [1]

X: _____

Y: _____

(c) Agnes made a cut around the stem of a plant in the garden as shown.

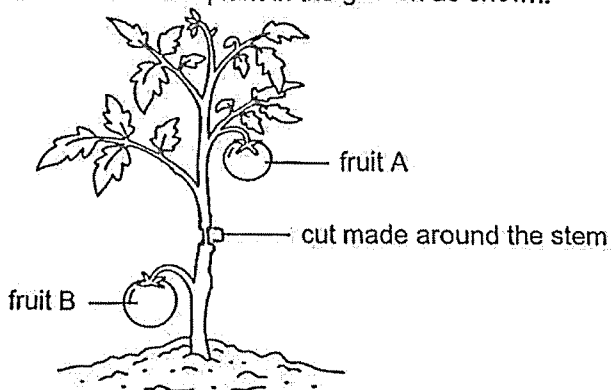

She watered the plant daily. After some weeks, she found that fruit A was much bigger in size than fruit B. Explain her observation. [2]

(Go on to the next page)

SCORE	4
-------	---

39. Alyssa prepared a chicken at room temperature and heated the oven to 180 °C. She placed the chicken in the oven to cook. After the chicken was cooked for one hour, she inserted a thermometer into the chicken to check the temperature as shown.

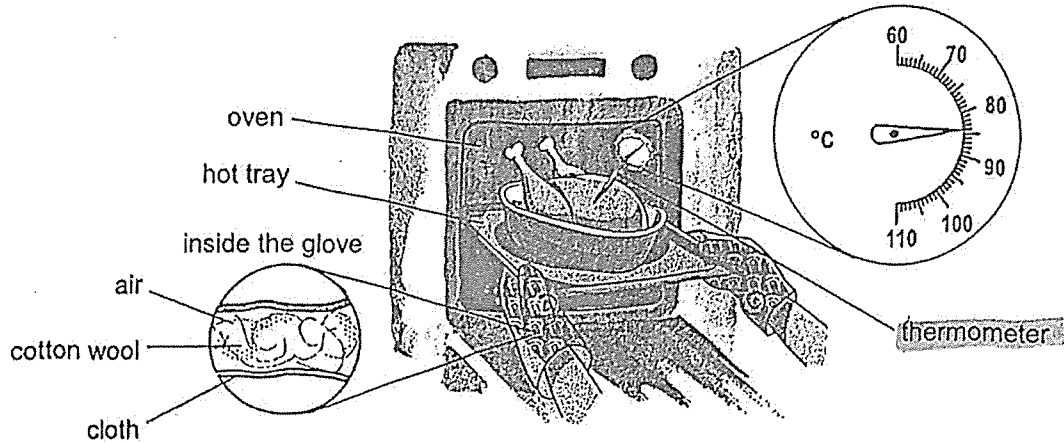

- (a) State the temperature shown on the thermometer. [1]

- (b) State why the temperature of the chicken is not 180 °C even after one hour in the oven. [1]

- (c) Alyssa wore oven gloves to remove the hot tray from the oven at 180 °C. Explain how the gloves protected Alyssa's hand from being burnt. [2]

(Go on to the next page)

SCORE	2
	4

40. A projector projects an image on the screen in a dark room as shown.

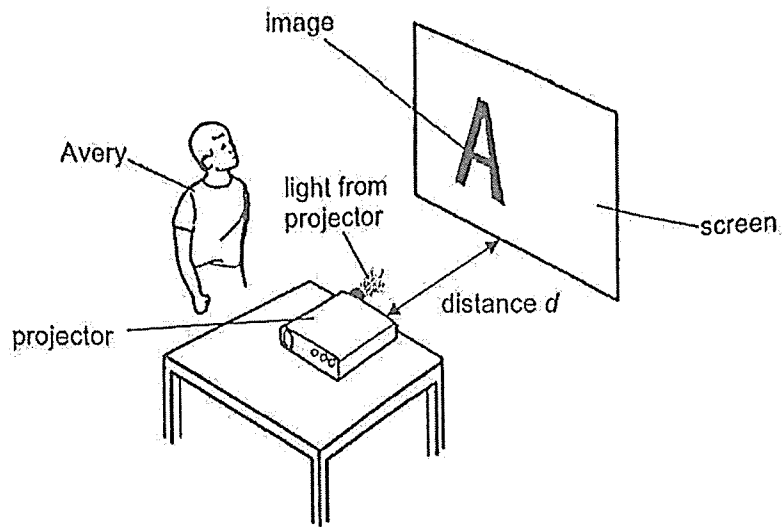

Avery moved the projector away from the screen at different distances and recorded the height of the image in the table.

Distance d (cm)	Height of image (cm)
60	16
90	30
120	44

(a) State the effect of increasing distance d on the height of image on the screen.

[1]

(b) State a property that the screen must have for the image to be projected on it.

[1]

(c) Explain how Avery is able to see the image on the screen.

[1]

(Go on to the next page)

SCORE	3
-------	---

41. Aditya set up the circuit in a toy using identical bulbs and batteries as shown. The circuit components were in working condition. When the steel balls are placed on the metal contacts, both bulbs A and B should light up.

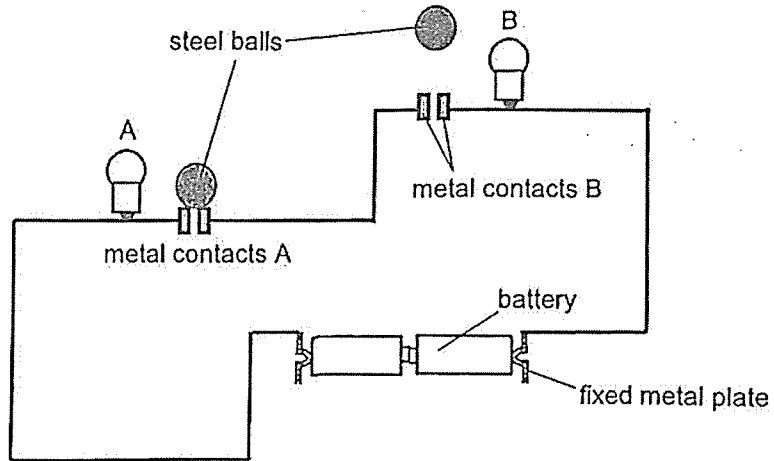

However, when the steel balls were on the metal contacts, the bulbs did not light up.

- (a) Use a pencil to complete the circuit below. [3]

- Correct the mistake(s) by drawing the two batteries and wires
- Connect the bulbs such that if one bulb fuses the other remains lit.

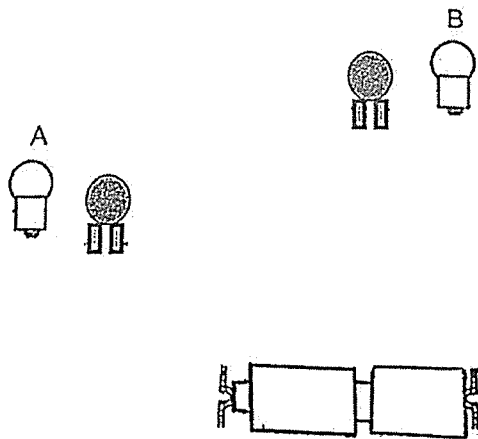

(Go on to the next page)

SCORE	3
-------	---

- (b) Aditya replaced the steel balls with two similar-sized plastic balls. State what he would observe about the bulbs. Explain your answer. [1]

End of Paper

SCORE	
-------	---

SCHOOL : ACS (JUNIOR)
LEVEL : PRIMARY 5
SUBJECT : SCIENCE
TERM : 2025 END OF YEAR EXAMINATION

Q1	Q2	Q3	Q4	Q5	Q6	Q7	Q8	Q9	Q10
3	2	2	2	3	4	4	1	3	3
Q11	Q12	Q13	Q14	Q15	Q16	Q17	Q18	Q19	Q20
3	1	3	2	3	2	4	3	2	4
Q21	Q22	Q23	Q24	Q25	Q26	Q27	Q28	Q29	Q30
2	2	4	3	2	3	3	1	2	3

31a	C, A, B
31b	<p>Claim: B</p> <p>Evidence: The volume of water in the beaker after five minutes is the most and remained unchanged.</p> <p>Reason: B is waterproof and does not absorb any water.</p> <p>Link: The raincoat can keep the user dry.</p>
32a	<p>Matter: Oxygen, Sand</p> <p>Non-matter: Light</p>
32bi	<p>Claim: Q</p> <p>Evidence: Distance X decreases for substance Q after pushing the plunger but remains the same for P.</p> <p>Reason: Q can be compressed but not P.</p> <p>Link: Only gas can be compressed.</p>
33a	X Y Z W
33b	It is sweet and juicy.

33c	When an animal passes through X, its hook-like structure clings onto the animal's fur/hair. When the animal moves further away from the parent plant, X drops and is dispersed further away from the parent plant.
34a	Liquid
34b	The warmer water vapour in the car comes into contact with the cooler inner surface of the window, loses heat and condenses into water droplets that appear as mist.
34c	The amount of mist formed will decrease. The temperature difference between the water vapour and the inner surface of the window will decrease so less water vapour will condense slower, forming less mist.
34d	Evaporation
35a	She wants to find out how the number of coils of wire around the nail affects the number of steel pins attracted.
35b	Increase the number of coils of wire around the nail to 12. Add more batteries (connected in series).
36a	Set-ups B and D. There is only one changed variable, number of leaves, the rest of the variables are kept the same.
36b	The amount of light exposed to the plants in set-ups B and D.
36c	The roots hold the plant firmly to the ground.
37a	Circulatory system. It transports digested food and oxygen through the blood to all parts of the body. It transports carbon dioxide through the blood away from the body for removal.
37b	Blood vessels, Heart Do Not Accept Blood
37c	1st Marking Point: Respiratory System The nose in the respiratory system takes in air containing oxygen from the surrounding. The air moves down the windpipe and into the lungs where gaseous exchange takes place and oxygen is absorbed into the bloodstream. 2nd Marking Point: Circulator System The oxygenated blood then flows to the heart where it pumps the blood to
38a	
38b	X: Water Y: Food

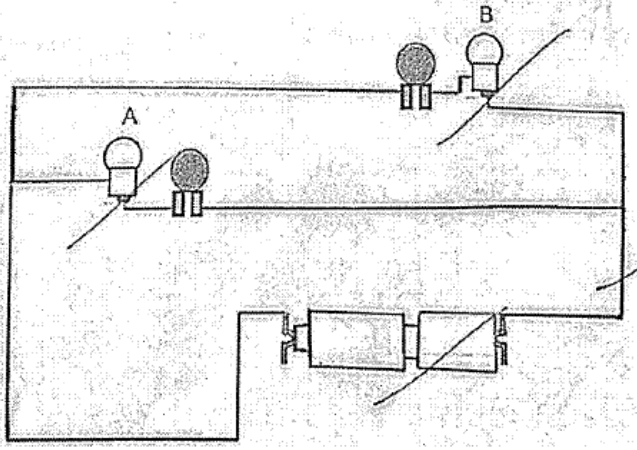
38c	The food made by the leaves could not be transported to fruit B as the food-carrying tubes were removed. More food is then transported to fruit A and more food stored in the fruit A.
39a	84°C
39b	The chicken is a poor conductor of heat and heat flows slowly to the chicken.
39c	The air, cotton wool and cloth are poor conductors of heat. Her hands gained heat from the hot tray slower and are not burnt.
40a	The height of the image on the screen increases.
40b	Opaque
40c	Light from the projector is reflected off the screen and into Avery's eyes.
41a	
41b	The bulbs would not light up. Plastic is an electrical insulator so there is an open circuit where electric current cannot flow through the bulbs.

